



Typical Features

- ◆ Wide input voltage range 64-280VDC
- ◆ No-load consumption $\leq 0.3W$
- ◆ Switching frequency (64-120VDC Typ.84%, 120-280VDC Typ.87%)
- ◆ Protection: short circuit, over-current, over-voltage protections
- ◆ Isolation voltage: 4000Vac
- ◆ Meet IEC/EN62368 test standard
- ◆ Comply with CE and RoHS certification standards
- ◆ Fully enclosed plastic case, complied with UL94V-0 level
- ◆ Plug-in mounting on PCB



Application Field

BK25-150S12H2N4-----is a small-sized, high-efficiency module power supply provided by Aipu. This series of power supplies has the advantages of global input voltage range, AC and DC dual-use, low ripple, low temperature rise, low power consumption, high efficiency, high reliability, high safety isolation, and good EMC performance. EMC and safety specifications meet international EN55032 and IEC/EN61000 standards. This series of products are widely used in many fields such as electric power, industry, instrumentation and smart home. When the product is used in a harsh electromagnetic compatibility environment, please refer to the application circuit provided by our company.

Typical Product List

Model	Output specifications			Max. Capacitive Load (μF)	Ripple & noise 20MHz(MAX) mVp-p	Full load efficiency, 150VDC (Typ.) %
	Power (W)	Voltage V_o (V)	Current I_o (mA)			
	BK25-150S12HN4	25	12	2100	2000	150

Note 1: The typical output efficiency is based on that product is full loaded and burned-in after half an hour.

Note 2: The fluctuation range of full load efficiency(% ,TYP) is $\pm 2\%$, full load output efficiency= total output power/module's input power.

Note 3: The test method for ripple and noise adopts the twisted pair test method. Please see the following (ripple & noise test instructions) for specific test methods and combinations.

Input Specification

Item	Operating Condition	Min.	Typ.	Max.	Unit
Input Voltage Range	DC Input	64	150	280	VDC
Input Current	64VDC	--	--	0.5	A
Surge Current	64VDC	--	20	--	
	280VDC	--	45	--	
No Load Consumption	Input 64 VDC	--	0.10	0.30	W
	Input 280 VDC	--			

Recommended External Fuse	2A/250VAC Slow Fusing
Hot Plug	Unavailable
Remote Control Terminal	Unavailable

Output Specification

Item	Operating Condition	Min.	Typ.	Max.	Unit
Output Voltage Accuracy	0%~100% load	--	±2.0	±3.0	%
Line Regulation	Nominal load	--	--	±0.5	
Load Regulation	20%~100% nominal load, balance load	--	--	±1.0	
Minimum Load	Single output	10	--	--	
Turn-on Delay Time	Input 64VDC (full load)	--	1500	--	mS
	Input 280VDC (full load)	--		--	
Power Off Holding Time	Input 64VDC (full load)	--	50	--	mS
	Input 280VDC (full load)	--		--	
Dynamic Response	Overshoot Range	25%-50%-25%	--	+5.0	%
	Recovery Time		50%-75%-50%		--
Output Overshoot	0%~100% load	≤10%Vo			%
Short circuit protection		Continuous, Self-recovery			Hiccup
Drift Coefficient	--	--	±0.03%	--	%/°C
Over-current Protection	0%~100% load	≥130% Io, self-recovery			Hiccup
Output Over-voltage Protection	Output 12V	--	--	16	VDC

General Specification

Item	Operating Condition	Min.	Typ.	Max.	Unit
Operating Temperature	--	-40	--	+85	°C
	Refer to Temperature Derating Curve, details see the Product Character Curve at back				
Storage Temperature	--	-40	--	+105	°C
Soldering Temperature	Wave-soldering	260±4°C, time: 5-10S			
	Manual-welding	360±8°C, time: 4-10S			
Relative Humidity	--	10	--	90	%RH
Isolation Voltage	Input-Output	Test for 1 minute, leakage current ≤5mA	4000	--	VAC
Insulation Resistance	Input-Output	@DC500V	100	--	MΩ
Safety Standard	--	IEC/EC62368			
Vibration	--	10-55Hz, 10G, 30Min, along X,Y, Z			
Safety Class	--	CLASS II			

Guangzhou Aipu Electron Technology Co., Ltd

Add: Building 4, HEDY Park, No.63, Punan Road, Huangpu Dist, Guangzhou, CN.
 Email: market@aipu-elec.com Tel: 86-20-84206763 Fax: 86-20-84206762 HOTLINE: 400-811-8032 Website: http://en.aipulnion.com/
 Guangzhou Aipu Electron Technology Co., Ltd reserves the copyright and right of final interpretation. Version:A0 Date: 2022-12-24 Page 2 of 5

Case Class	--	UL94V-0
Mean Time Between Failures	--	MIL-HDBK-217F 25°C>300,000H

Physical Specifications

Case Material	Black Aluminum Case (UL94V-0)	
Package Dimensions	70.0X48.0X23.5mm	
Product Weight	115g (TYP)	
Cooling Method	Free Air Convection	

EMC External Recommended Circuit

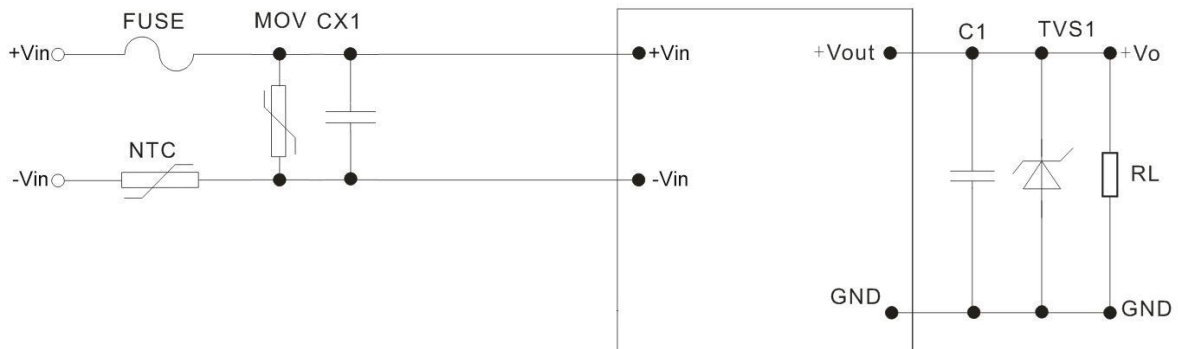

Picture 1

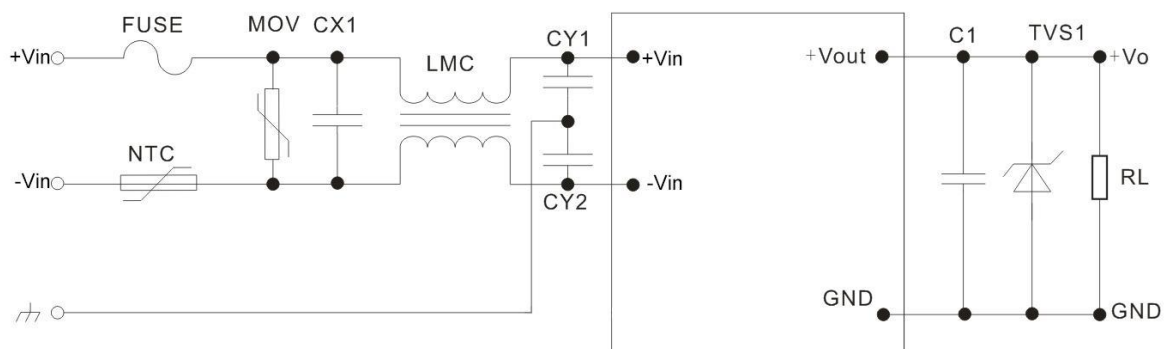

Picture 2

Note:

- To remove high-frequency noise, the output filter capacitor C1 is recommended to be a 1 μ F ceramic capacitor, and the capacitor withstand voltage derating is greater than 80%.
 - It is recommended to use TVS tube to protect the downstream circuit (when the module is abnormal). It is recommended to use the 600W model.
- 5V output recommended use: SMBJ7.0A, 9V output recommended use: SMBJ12.0A, 12V output recommended use: SMBJ20A, 15V output recommended use: SMBJ20.0A, 24V Recommended output: SMBJ30.0A, 48V Recommended output: SMBJ64A
- MOV is a varistor, recommended model: 10D561K, which is used to protect the module from damage during lightning surges.
 - For customers' general application requirements, use the recommended circuit in Figure 1. If there are higher EMC requirements, please use the recommended circuit in Figure 2. Figure 2 The specific recommended values are as follows:
 - Varistor MOV: Recommended model: 10D-561K, used to protect the module from damage during lightning surges.
 - Thermistor NTC: 10D-9;
 - Safety capacitors CY1 and CY2: 1000pF/400VAC;
 - Safety capacitor CX: 0.1 μ F/275VAC;

5) Common mode inductor LCM: 15mH-30mH;

6). FUSE (fuse): Must be connected, recommended specification is 3.15A/250V, slow fusing.

Dimension and Pin out Specifications

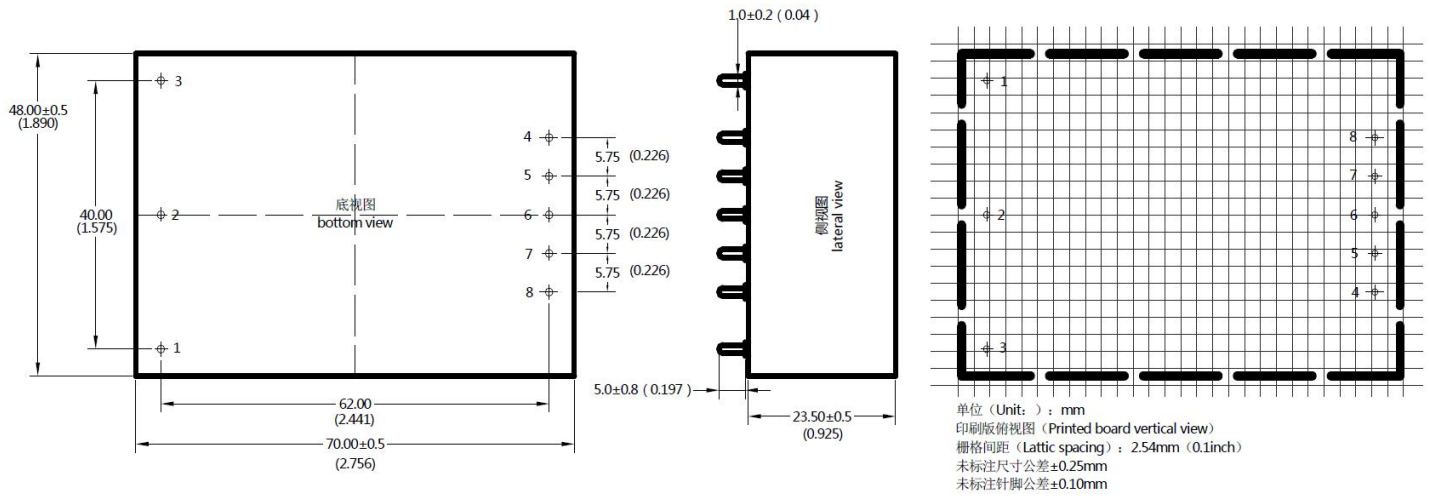

Pin out Specification:

Pin-out	1	2	3	4	5	6	7	8
Dual (S)	NP	-Vin	+Vin	+Vo	NP	NP	GND	NP

Dimension

Packing code	L x W x H	
H1N4	70.0X48.0X23.5 mm	2.756X1.890X0.925inch

Ripple & Noise Test: (Twisted Pair Method 20MHZ bandwidth)

Test Method:

(1) 12# twisted pair to connect, Oscilloscope bandwidth set as 20MHz, 100M bandwidth probe, terminated with 0.1uF polypropylene capacitor and 10uF high frequency low resistance electrolytic capacitor in parallel, oscilloscope set as Sample pattern.

(2) Input terminal connect to power supply, output terminal connect to electronic load through jig plate, Use 30cm±2 cm sampling line, Power line selected from corresponding diameter wire with insulation according to the flow of output current.

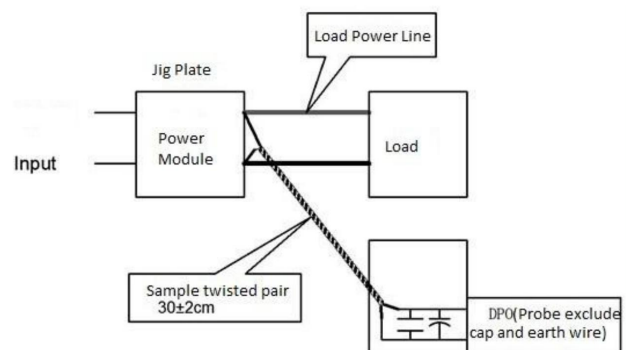

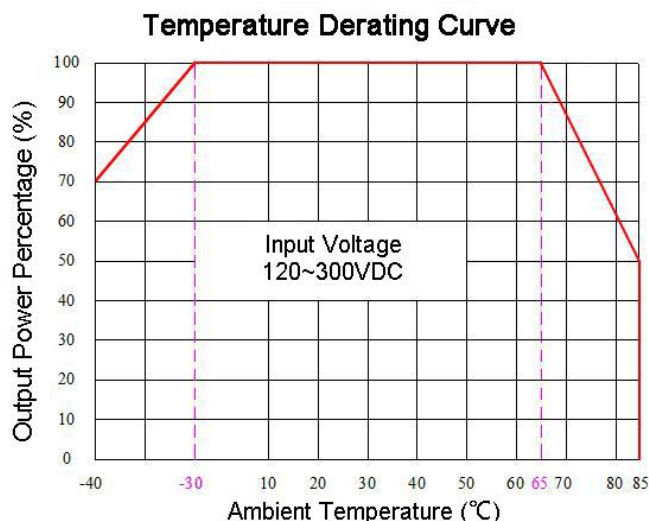
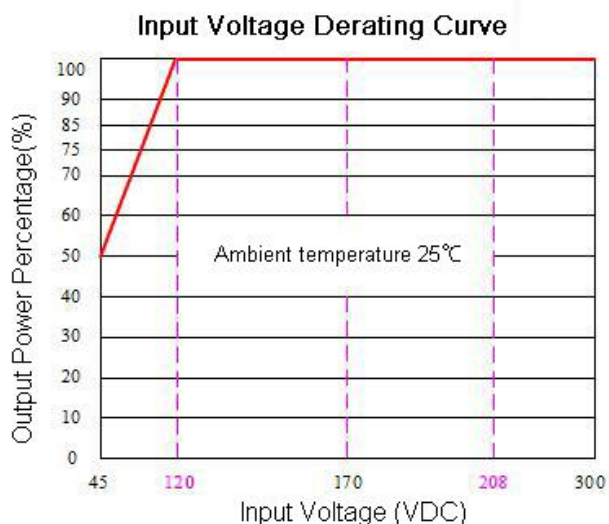

Note 1: When the input voltage is 45~120VDC and the temperature is -40~85 °C , voltage derating must be performed based on the input voltage derating curve.

Note 2: This product is suitable for use in a natural wind cooling environment. If it is used in a closed environment, please contact our company.

Note:

- 1.The product should be used under the specification range, otherwise it will cause permanent damage to it.
- 2.Product's input terminal should connect to fuse;
- 3.If the product operated below the minimum load request, we cannot ensure that the performance of product is in accordance with all the indexes in this manual;
- 4.If the product worked beyond the load range, we cannot ensure that the performance of product is in accordance with all the indexes in this manual;
- 5.Unless otherwise specified, data in this datasheet are tested under conditions of Ta=25°C, humidity<75% when inputting nominal voltage and outputting rated load(pure resistance load);
- 6.All index testing methods in this datasheet are based on our Company's corporate standards.
- 7.The performance indexes of the product models listed in this manual are as above, but some indexes of non-standard model products will exceed the above-mentioned requirements, please directly contact our technician for specific information;
- 8.We can provide customized product service;
- 9.The product specification may be changed at any time without prior notice.