

Typical Feature

- ◆ Wide input voltage range: 85-265VAC/120-380VDC
- ◆ Transfer efficiency (typ. 87%)
- ◆ Switching frequency: jitter frequency in 100KHz
- ◆ Protection: over current, short circuit, over temperature, self-recovery
- ◆ Input-output highly isolated 3000Vac
- ◆ PCB Mounting



Application field

FA8-220SXXD2 Series ----- a compact size, high efficient, meet CE standard power modules offered by Aipu. It features universal input voltage range, DC and AC dual input, low ripple, low temperature rise, low power consumption, high efficiency, high reliability, safer isolation. It offers good EMC performance, EMC and Safety specifications meet international EN55032, IEC61000 standards. It widely used in industrial, office and civil applications. For harsh EMC environment, the application circuit in the datasheet is strongly recommended.

Typical Product List

Certification	Type	Power (W)	Output		Max capacitive load	Ripple and noise 20MHz	Efficiency@ full load, nominal input voltage (typical value)%
			Voltage	Current			
			Vo1(V)	Io1(mA)			
/	FA8-220S3V3D2	6.6	3.3	2000	1000	120	80
	FA8-220S3V6D2	6.5	3.6	1800	1000	120	80
	FA8-220S3V8D2	6.5	3.8	1700	1000	120	80
	FA8-220S05D2	8	5	1600	1000	120	81
	FA8-220S12D2	8	12	667	1000	120	83
	*FA8-220S24D2	8	24	333	800	120	87

Note:

1. Due to space limitations, above is only a part of our product list, please contact our sales team for more items.
2. “*” are models being developing.
3. The typical output efficiency is based on that product is full loaded and burned-in after half an hour.
4. The fluctuation range of full load efficiency(% , TYP) is ±2%, full load output efficiency= total output power/module’s input power.

Technical Parameters Test Condition: Unless otherwise specified, data in the datasheet should be tested under the conditions of inputting nominal voltage, pure resistance rated load and Ta=25 °C.

Input Specifications:

Items	Operating Condition	Min	Typical	Max	Note
Input voltage range	AC input	85	220	265	VAC
	DC input	120	310	380	VDC

Input frequency range	/	47	50	63	Hz
Input current	100VAC~47Hz	/	/	200	mA
	220VAC~50Hz	/	/	100	
Input inrush current	110VAC~47Hz	/	10	/	A
	230VAC~50Hz	/	20	/	
Recommended External Input Fuse	/	2A~250Vac slow fusing, block form			

Output Specifications

Voltage accuracy	Any load, full voltage range	Vo1	±2.0%
Line Regulation	Nominal load, full voltage range	Vo1	±0.5%
Load Regulation	20% ~ 100% rated load	Vo1	±1.0%
Ripple & Noise	20MHz BM full load	≤120mVp-p	/
	The ripple and noise should be tested under the condition of twisted-pair test. (See the ripple and noise test at back)		
No Load Power Consumption	Full input voltage range	Max	0.1W
Turn-on Delay Time	Input nominal voltage	Typical value	2000mS
Output Power-off Holding Time			10mS
Dynamic Response	25%~50%~25%	Overshoot range (%): ≤±5.0	%
	50%~75%~50%	Recovery time (mS) ≤5.0	mS
Output short-circuit protection	Self-recovery	Output Switch-off	Hiccup
Output over load protection	≥150% Po (220VAC Input)	Output Switch-off	Hiccup
Temperature drift coefficient	/	±0.03	%/°C

General Specifications

Switching frequency	80KHZ	100KHz Typical	125KHZ
Working temperature	/	Free air convection	-25°C ~ +65°C
Storage temperature	/	/	-40°C ~ +105°C
Relative humidity	/	/	10%~90%
Isolation voltage/ insulation resistance	Input and output 3000Vac ≤ 3.0mA/1min; Input and output ≥100MΩ (Test voltage is DC 500V)		

EMC Electromagnetic Compatibility

EMC	EMI	CE	CISPR22/EN55032/EN55024	CLASS B(recommend circuit see attached photo 1)
		RE	CISPR22/EN55032/ EN55024	CLASS B(recommend circuit see attached photo 1)
	EMS	RS	IEC/EN61000-4-3 10V/m	Perf.Criteria B(recommend circuit see attached photo 1)
		CS	IEC/EN61000-4-6 3Vr.m.s	Perf.Criteria B (recommend circuit see attached photo 1)
		ESD	IEC/EN61000-4-2 Contact ±4KV	Air ±8KV (recommend circuit see attached photo 1)
		Surge	IEC/EN61000-4-5 ±1KV	Perf.Criteria B(recommend circuit see attached photo 1)
		EFT	IEC/EN61000-4-4 ±2KV	Perf.Criteria B(recommend circuit see attached photo 1)
	Voltage dips, short interruptions and voltage variations immunity		IEC/EN61000-4-11 0%~70%	Perf.Criteria B
Vibration		10-55HZ,10G,30Min,alongX,Y,Z		
MTBF		2X10 ⁵ Hrs		
Grade of case material		plastic		

Dimension

Unit: mm(inch);
Printed board vertical view
Grid:2.54mm(0.1inch);
General tolerances: ±0.25mm;
General Pin tolerances: ±0.10mm

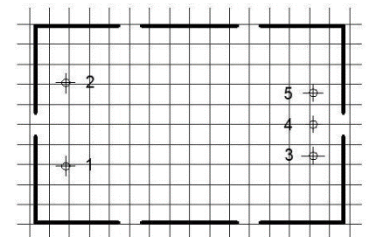
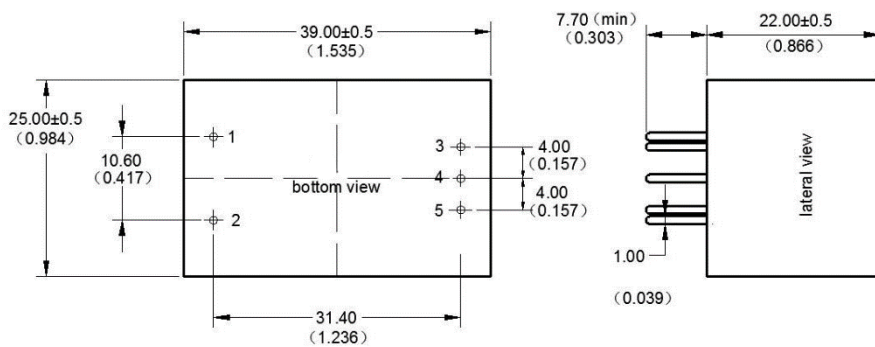

Packing code	L x W x H	
D2	39.0X25.0X22.0 mm	1.535X 0.984X0.866inch

Pin definition

Pin	1	2	3	4	5
Single(S)	AC(L)	AC(N)	+Vo	NP	-Vo

Note: If the definition of pin is not in accordance with the model selection manual, please refer to the label on actual item.

Ripple & noise test: (Twisted-pair method 20MHZ bandwidth)

Test method:

1. The ripple and noise test is to connected the 12#twisted-pair wire, the bandwidth of the oscilloscope is set to 20MHZ, 100M bandwidth probe, the 0.1uF polypropylene capacitor and 10uF high-frequency low-resistance electrolytic capacitance are parallel to the probe end. The oscilloscope is set to the sample mode.

2. Output ripple noise test diagram:

The input end of the power supply is connected to the input power supply, the power output is connected to the electronic load through the fixture board, and the test is sampled directly from the output port of the power source by 30cm ± 2 cm sampling line. The power line selects the insulated conductor with the corresponding diameter according to the output current.

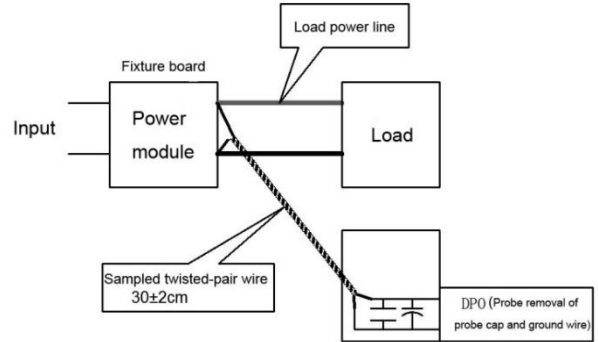

Working Temperature Derating Curve

Input Voltage Derating Curve

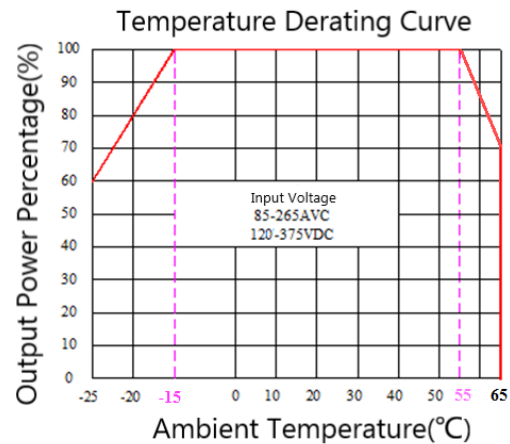
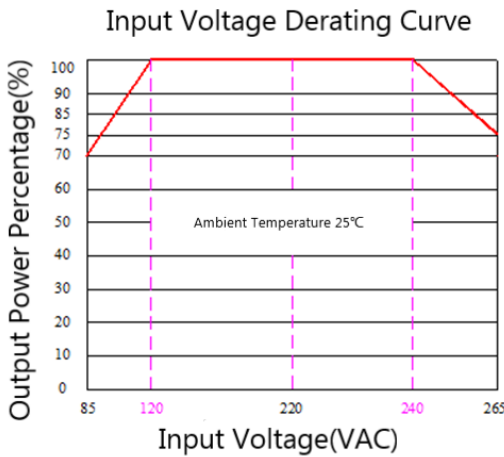

Note:

- 1: Input voltage should be derated based on input voltage derating curve when it is 85~100VAC/240~265VAC/120~140VDC/340~380VDC.
- 2: Our product is suitable to use under natural air cooling environment, if use it under closed condition, please contact with us.

Typical EMC application circuit (recommended parameter)

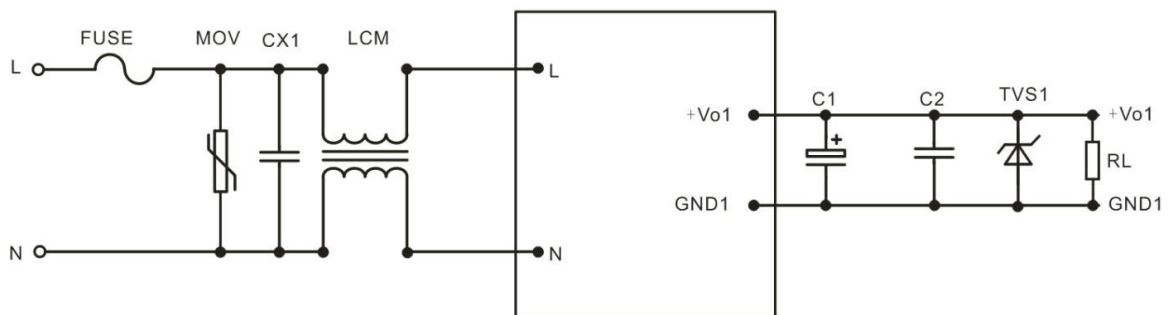

Photo 1

**Note:**

1. Fuse, recommend 2A~250Vac slow fusing, block form;
2. MOV is voltage dependent resistor, recommended model is 14D561k;
3. CX1 is X capacitor, the recommended model is 0.1uF/275Vac;
4. LCM is common mode inductor, the recommended model is 30mH;
5. C1 choose high frequency low impedance electrolytic capacitor, the capacitance value less than capacitive load. Withstand voltage is 1.5 times more than output voltage;
6. C2 choose 0.1uF ceramic chip capacitor, withstand voltage is 1.5 times more than output voltage;
7. TVS1 is TVS tube, 5V output recommended: SMBJ7.0A, 9V output recommended:SMBJ12.0A, 12V output recommended: SMBJ20A, 15V output recommended:SMBJ20.0A, 24V output recommended:SMBJ30.0A, 48V output recommended:SMBJ64A.

Note:

1. The product should be used under the specification range, otherwise it will cause permanent damage to it.
2. Product's input terminal should connect to fuse;
3. If the product worked beyond the load range, we cannot ensure that the performance of product is in accordance with all the indexes in this manual;
4. Unless otherwise specified, data in this datasheet should be tested under conditions of $T_a=25^{\circ}\text{C}$, humidity<75% when inputting nominal voltage and outputting rated load(pure resistance load);
5. All index testing methods in this datasheet are based on our Company's corporate standards
6. The performance indexes of the product models listed in this manual are as above, but some indexes of non-standard model products will exceed the above-mentioned requirements, and please directly contact our technician for specific information;
7. We can provide customized product service;
8. The product specification may be changed at any time without prior notice.