



### Product Typical Features

- ◆ Wide input voltage range ( 4:1), Output Power 12W
- ◆ Transfer Efficiency up to 88%
- ◆ Stand-by Power Consumption as low as 0.15W
- ◆ Output super-fast start up
- ◆ Continuous Short Circuit protection, Self-recovery
- ◆ Input under voltage, output over voltage, short circuit, over current protection
- ◆ Switching Frequency 330KHz
- ◆ Isolation Voltage 1500VDC
- ◆ Operating Temperature: -40°C~+85°C
- ◆ Good EMI performance
- ◆ International standard pin-out



### Application Field

**PFD12-XXDXXA3(C)2** is a newly designed DIP 1X1 packed, 12W output power, ultra wide input range 4:1, low stand-by power consumption, isolated regulated output DC-DC converter, could be widely used for industrial control, instrument, communication, power electricity, internet of things field. For harsh EMC environment, the application circuit in the datasheet is strongly recommended.

### Typical Product List

Part No	Input Voltage Range (VDC)		Output Voltage/Current (Vo/Io)		Input Current (mA) Nominal Voltage		Max. Capacitive Load uF	Ripple & Noise		Efficiency (%)@output full load, input nominal voltage	
	Nominal	Range	Voltage (VDC)	Current(mA) MAX./Min.	Full load typ.	No Load typ.		mVp-p		Min	Typ
								Typ.	Max.		
PFD12-18D05A3(C)2	24	9-36	±5	±1200/0	595	10	3000	50	100	82	84
PFD12-18D09A3(C)2	24	9-36	±9	±667/0	588	10	2000	50	100	83	85
PFD12-18D12A3(C)2	24	9-36	±12	±500/0	574	10	1500	50	100	85	87
PFD12-18D15A3(C)2	24	9-36	±15	±400/0	568	10	1000	50	100	86	88
PFD12-18D24A3(C)2	24	9-36	±24	±250/0	574	10	300	50	100	85	87
PFD12-36D05A3(C)2	48	18-75	±5	±1200/0	297	10	3000	50	100	82	84
PFD12-36D09A3(C)2	48	18-75	±9	±667/0	294	10	2000	50	100	83	85
PFD12-36D12A3(C)2	48	18-75	±12	±500/0	287	10	1500	50	100	85	87
PFD12-36D15A3(C)2	48	18-75	±15	±400/0	284	10	1000	50	100	86	88
PFD12-36D24A3(C)2	48	18-75	±24	±250/0	287	10	500	50	100	85	87

1. "C" with control pin, "N" without control pin;
2. Max capacitive load is, when the power supply is fully loaded, the max capacity could be connected to output, if exceed, the power supply cannot start-up;

### Input Specification

Stand-by Consumption	0.15 W(TYP)		
Input Filter	π filter		
Input Under-Voltage Protection	Typ: 7.3VDC@PFD12-18DXXA3(C)2 Input		
	Typ: 14VDC@PFD12-36DXXA3(C)2 Input		
CTRL*	Module turn-on	CTRL suspended or TTL high level (3.3-12VDC)	
	Module turn-off	CTRL connect to -Vin or low level (0-0.7VDC)	
	Input current when switched off	2mA (TYP)	

Note: \*The voltage of CTRL pin is relative to -Vin pin.

### Output Specification

Main Circuit Output Voltage Accuracy	Full voltage full load	Vo	±2.0%(max)
Auxiliary Circuit Output Voltage Accuracy	Full voltage full load	Vo	±3.0%(max)
Voltage Regulation	Nominal load, full voltage	Vo	Main circuit: ≤±0.5%; auxiliary circuit ≤±1%
Load Regulation	5% ~ 100% nominal load	Vo	≤±1.0%
Ripple & Noise	Twisted Pair Method, 20M Hz bandwidth; 5%~100% load		50mVp-p typ, 100mVp-p max
Output Over-voltage Protection	110%~160%Vo		
Output Over-load Protection	110%~300%Io		
Output Short circuit Protection	Continuous, Self-recovery		
Dynamic Response	25% nominal load step change ΔVo/Δt		±3% typ , ±5% max /500us
Cross Regulation	Main Circuit 50% load, Auxiliary Circuit 10~100% load		≤±5.0%
Turn-on delay time	Typical	10ms	
Output Turn-on Overshoot Voltage	≤10%Vo		

Note: 0% - 5% of load ripple & noise is less than or equal to 5% Vo.

### General Specification

Switching Frequency	Typical	330KHz
Operating Temperature	Refer to Temperature Derating Curve	-40°C ~ +85°C

Storage Temperature		-55℃ ~ +125℃
Max Case Temperature	Within Operating Curve	+105℃
Relative Humidity	No condensing	5%~95%
Case Material		Aluminum Metal Case
Cooling Method		Free air convection
Isolation Voltage	Input to Output	1500Vdc ≤ 0.5mA / 1min
Meantime Between Failure	MIL-HDBK-217F@25℃	2X10 <sup>5</sup> Hrs
Product Weight	Average	18g

### EMC Characteristics

Total Items	Sub Items	Test Standard	Class
EMC	EMI	CE	CISPR22/EN55032 CLASS B (see recommended circuit photo ②)
		RE	CISPR22/EN55032 CLASS B (see recommended circuit photo ②)
	EMS	RS	IEC/EN61000-4-3 10V/m Perf.Criteria B (see recommended circuit photo 2)
		CS	IEC/EN61000-4-6 3Vr.m.s Perf.Criteria B(see recommended circuit photo 2)
		ESD	IEC/EN61000-4-2 Contact ±4KV Perf.Criteria B
		Surge	IEC/EN61000-4-5 ±2KV Perf.Criteria B (see recommended circuit photo 1)
		EFT	IEC/EN61000-4-4 ±2KV Perf.Criteria B (see recommended circuit photo 1)
		Voltage dips and interruptions	IEC/EN61000-4-11 0%~70% Perf.Criteria B

### A3 Packing Dimension

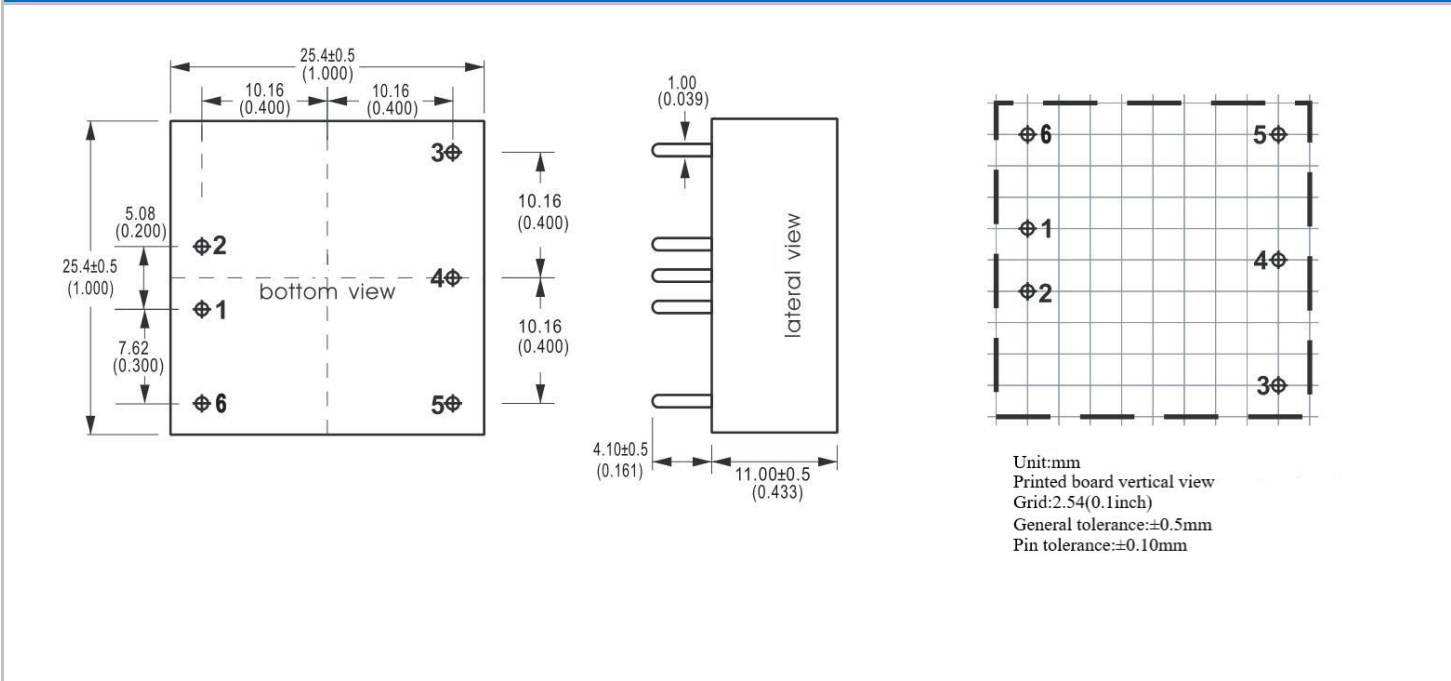

Packing Code	L x W x H	
A3	25.4X 25.4X11 mm	1X1 X0.433inch

### Pin Definition



Series	1	2	3	4	5	6
PFD12-XXDXXA3N2	-Vin	+Vin	+Vout	COM	-Vout	NP
PFD12-XXDXXA3C2	-Vin	+Vin	+Vout	COM	-Vout	CTRL

**Ripple & Noise Test: (Twisted Pair Method 20MHz bandwidth)**

**Test Method:**

- a. 12# twisted pair to connect, Oscilloscope bandwidth set as 20MHz, 100M bandwidth probe, terminated with 0.1uF polypropylene capacitor and 10uF high frequency low resistance electrolytic capacitor in parallel, oscilloscope set as Sample pattern.
- b. Input terminal connect to power supply, output terminal connect to electronic load through jig plate, Use 30cm±2 cm sampling line, Power line selected from corresponding diameter wire with insulation according to the flow of output current.

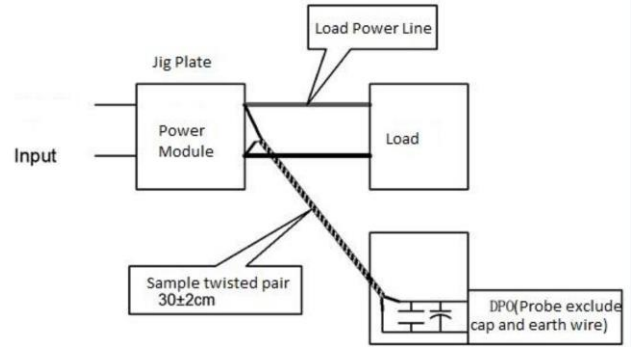

**Application Reference:**

1. Recommended minimum load is 5% or above 100uF high frequency low resistance electrolytic capacitor;
2. Recommend the unbalance loads of dual output to be ≤±5%;
3. The maximum capacitive load is test under the pure resistance full load condition.

**Product Characteristic Curve**

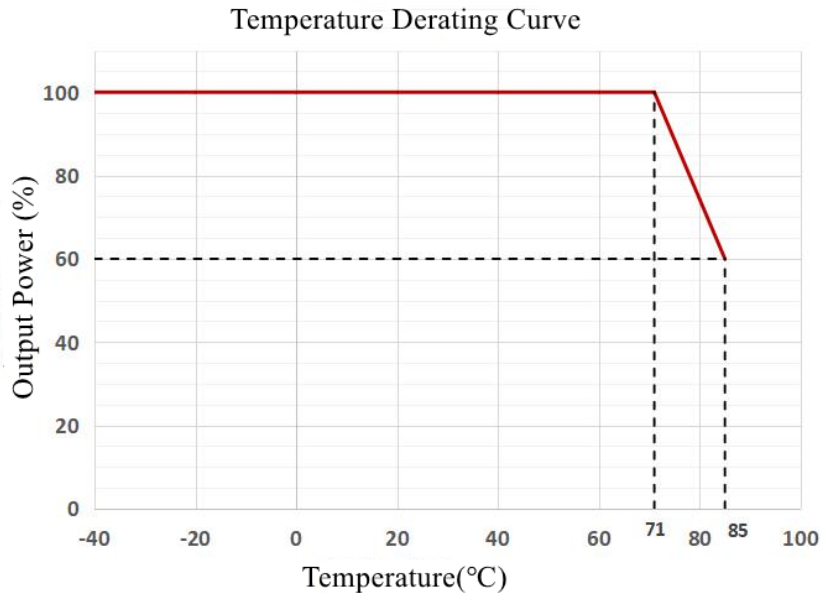

**Design Application**

**Recommended circuit**

**1. DC/DC test circuit:**

Normal recommended capacitors: C0:47-100uF; C1:100uF.

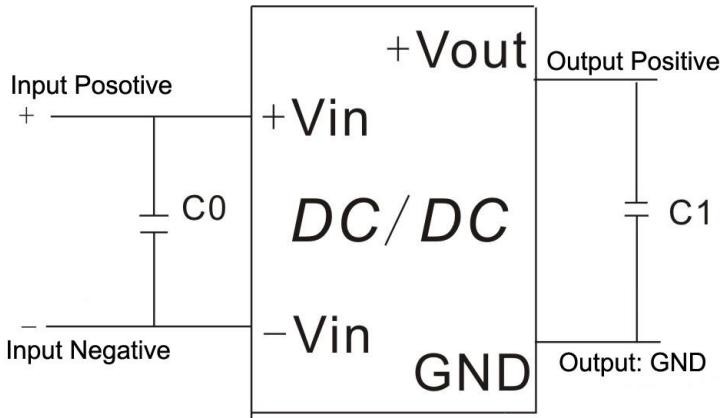

**2. Input reflecting ripple current test circuit:**

Capacitor C choose low ESR ones, withstand voltage value should be bigger than max input voltage;

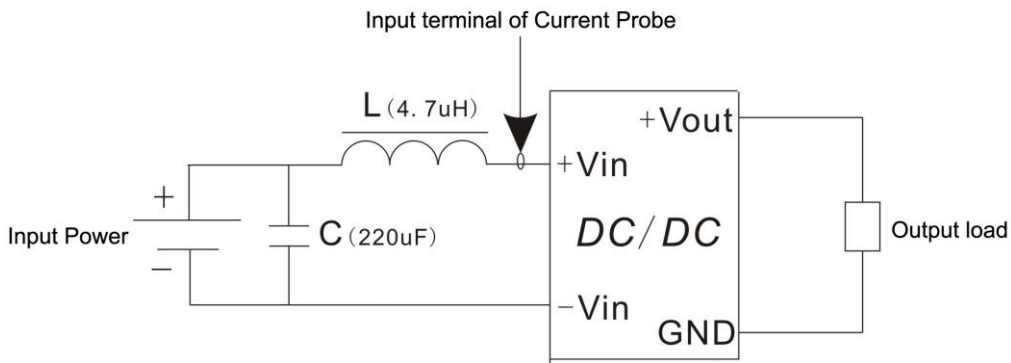



**3.EMC external recommended circuit:**

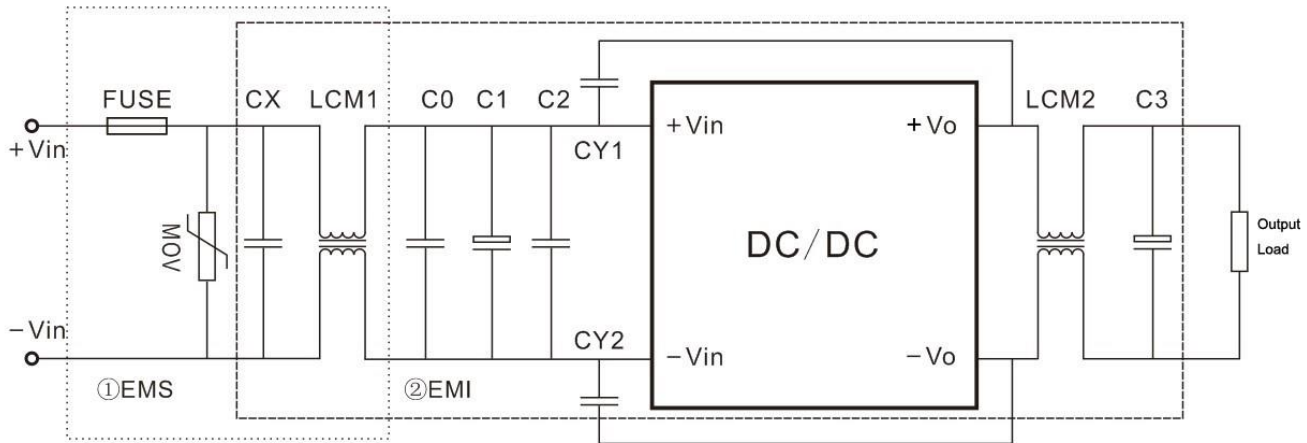

Component	PFD12-18DXXA3C2 Input	PFD12-36DXXA3C2 Input
FUSE	According to customer's request	
MOV	14D560K	14D101K
CX	0.47uF	0.47uF
LCM1	10mH	10mH
C0	1uF/100V	1uF/100V
C1	220uF/100V	220uF/100V
C2	1uF/100V	1uF/100V
LCM2	30uH	30uH
C3	47uF/50V	47uF/50V
CY1,CY2	1nF/2000V	

**Note:**

1. The product should be used under the specification range, otherwise it will cause permanent damage to it.
2. If the product worked beyond the load range or below the minimum load, we cannot ensure that the performance of product is in accordance with all the indexes in this manual;
3. Unless otherwise specified, data in this datasheet should be tested under conditions of Ta=25℃, humidity<75% when inputting nominal voltage and outputting rated load(pure resistance load);
4. All index testing methods in this datasheet are based on our Company' s corporate standards
- 5.The performance indexes of the product models listed in this manual are as above, but some indexes of non-standard model products will exceed the above-mentioned requirements, and please directly contact our technician for specific information;
6. We can provide customized product service;
7. The product specification may be changed at any time without prior notice.