

Typical Features

- ◆ Fixed input voltage, Isolated & regulated output, Output power 1W
- ◆ Operating Temperature: -40°C ~ +85°C
- ◆ Isolation Voltage 3000VDC
- ◆ High Efficiency up to 83%
- ◆ Continuous short circuit protection
- ◆ No load current as low as 4mA
- ◆ No external components needed
- ◆ Plastic Case, meet UL94 V-0 standard



Test Condition: Unless otherwise specified, data in the datasheet should be tested under the conditions of inputting nominal voltage, pure resistance rated load and Ta=25°C

Application Field

It could be widely used for instrument, telecommunication, pure digital circuit, general low frequency analog circuit, relay drive circuit, data exchange circuit, etc.

Typical Product List

Model	Input Voltage Range (VDC)		Output Voltage/Current (Vo/Io)		Input Current(mA) Nominal Voltage		Max. Capacitive Load uF	Ripple & Noise (Max.) mVp-p	Efficiency (%)full load, input nominal voltage	
	Nominal	Range	Voltage (VDC)	Current(mA) MAX./Min.	Full load Typ.	No Load Typ.			Min.	Typ.
NW1-05D05D3R3	5	4.75 - 5.25	±5	±100	258	11	2000	100	78	81
NW1-05D09D3R3			±9	±56	246	14	2000	100	77	80
NW1-05D12D3R3			±12	±42	238	17	2000	100	79	82
NW1-05D15D3R3			±15	±33	246	25	2000	100	77	80
NW1-12D05D3R3	12	11.4 - 12.6	±5	±100	104	5	2000	100	77	80
NW1-12D09D3R3			±9	±56	102	6	2000	100	80	83
NW1-12D12D3R3			±12	±42	102	8	2000	100	78	81
NW1-12D15D3R3			±15	±33	98	11	2000	100	80	83
NW1-24D05D3R3	24	22.8 - 25.2	±5	±100	52	4	2000	100	77	80
NW1-24D12D3R3			±12	±42	51	6	2000	100	79	82
NW1-24D15D3R3			±15	±33	51	8	2000	150	80	83

Note: In order to ensure the converter can work reliably with high efficiency, the minimum load should not less than 10% rated load when it is used. If the needed power is indeed small, please parallel a resistor at the output side, the resistance recommended equal to 10% nominal power.



Input Specifications

Item	Conditions	Min.	Typ.	Max.	Unit
Input Surge Voltage(1sec.max.)	5Vdc input	-0.7	--	9	Vdc
	12Vdc input	-0.7	--	18	
	24Vdc input	-0.7	--	30	
Input Filter	Capacitor Filter				
Hot Plug	Not available				

Output Specifications

Item	Working Conditions	Min.	Typ.	Max.	Unit
Output Power	Nominal input, Full load	0.1	--	1	W
Output Voltage Accuracy		--	±1.0	±3.0	%
Line Regulation	Input Voltage Change±1%	--	--	±0.25	
Load Regulation	10% ~ 100% nominal load	--	±0.5	±1.0	
Ripple & Noise①	Nominal input, full load, 20MHZ bandwidth	--	60	100	mV
Temperature Drift Coefficient	100% Full Load	--	--	±0.03	%/°C
Capacitive Load	Full input voltage range, full load	--	--	2000	uF
Output Short Circuit Protection	Continuous				

NOTE:①Ripple & Noise tested by twisted-pair method,

General Specifications

Item	Test conditions	Min.	Typ.	Max.	Unit
Switching Frequency	100% load, 5Vdc input	--	260	--	KHz
	100% load, 12Vdc/24Vdc input	--	450	--	
Isolation Voltage	I/P-O/P, test 1 minute, leakage current < 0.5mA	3000	--	--	VDC
Insulation Resistance	I/P-O/P, Insulation voltage 500VDC	1000	--	--	MΩ
Isolation Capacitance	I/P-O/P, 100KHz/0.1V	--	20	--	PF
MTBF	MIL-HDBK-217F@25°C	3500			
Case Material	Black flame-retardant heat-resistant Plastic(UL94 V-0)				
Pin Withstand Soldering Temp	Distance to case 1.5mm, 10S	300°C MAX			
Product Weight	4.5g(Typ.)				
Packing	Tube(525*18*10mm)	7PCS			
	Box(542*110*155mm)	336PCS(Total 48 Tubes)			

Packing Dimension

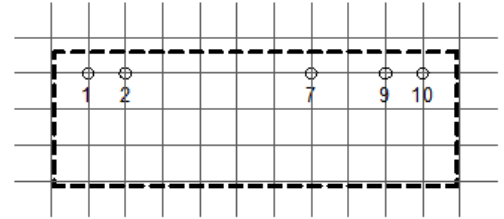
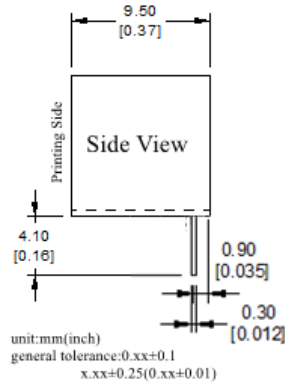
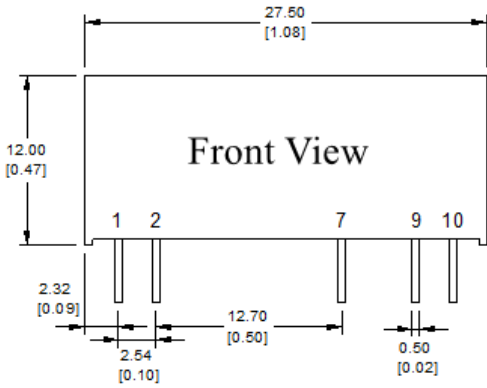

Printed board vertical view

Latic spacing: 2.54mm(0.1inch)

Packing Code	L x W x H	
D	27.50x 9.50 x 12.00mm	1.08 x 0.374x 0.472inch

Pin Function

Pin Function	1	2	7	9	10
Dual(D)	+Vin	GND	+Vo	-Vo	0V

Note: if the definition of pin is not in accordance with the model selection manual, please refer to the label on actual item.

Ripple & Noise Test: (Twisted Pair Method 20MHZ bandwidth)

Test Method:

a. 12# twisted pair to connect, Oscilloscope bandwidth set as 20MHZ, 100M bandwidth probe, terminated with 0.1uF polypropylene capacitor and 10uF high frequency low resistance electrolytic capacitor in parallel, oscilloscope set as Sample pattern.

b. Input terminal connect to power supply, output terminal connect to electronic load through jig plate, Use 30cm±2 cm sampling line, Power line selected from corresponding diameter wire with insulation according to the flow of output current.

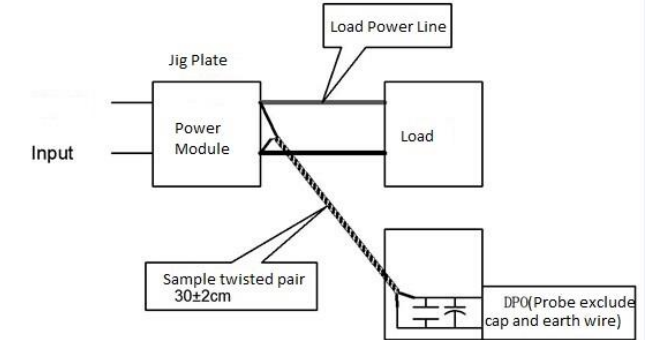

Temperature Curve

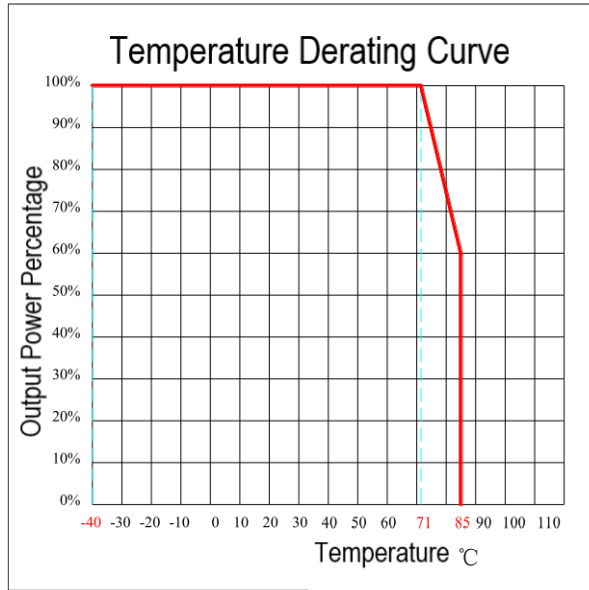

Design and Application Circuit Recommended

1. Output load requirements

- a. In order to ensure the converter can work reliably with high efficiency, the minimum load should not less than 10% rated load when it is used. If the needed power is indeed small, please parallel a resistor at the output side, the resistance equal to 10% nominal load.
- b. The maximum capacitive load is tested under nominal input full load, and cannot exceed the maximum capacitive load of output terminal under operation, otherwise it will cause it difficult to start up and damage the product.

2. Recommended circuit

In order to ensure the input/output ripple and noise decreased, capacitor filter net could be connected to input and output terminal, application circuit as below photo 1; choosing suitable filter capacitor is very important, start-up problems may be caused by too large capacitance. To ensure the modules running safely and reliably, the recommended capacitive load values as shown in Table 1. (But for the actual output power of application circuit is less than 0.5W, suggest not to connect external capacitor)

Recommended Capacitive Load (Table 1)

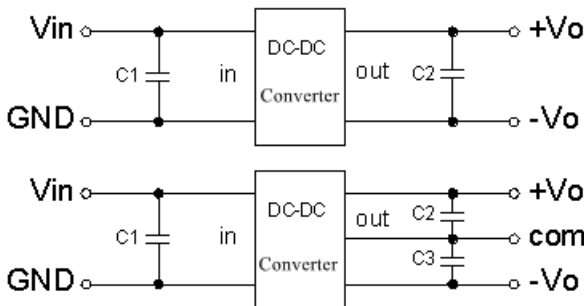

Vin (Vdc)	C1 (μF)	Vout (Vdc)	C2 (μF)	Vout (Vdc)	C2,C3 (μF)
3.3/5	4.7	3.3/5	10	±3.3/±5	4.7
12	2.2	9	4.7	±9	2.2
15	1	12	2.2	±12	1
24	1	15	1	±15	0.47
--	--	24	0.47	±24	0.22



3. Output regulated voltage and over voltage protection circuit

The simplest device to protect output regulated voltage, over voltage and over current is to cascade a linear regulator with overheat protection at input or output terminal, and connect a capacitor filter net(see below picture), filter capacitive value recommended see table 1, Linear regulator is chosen according to the actual voltage, current needed in working.

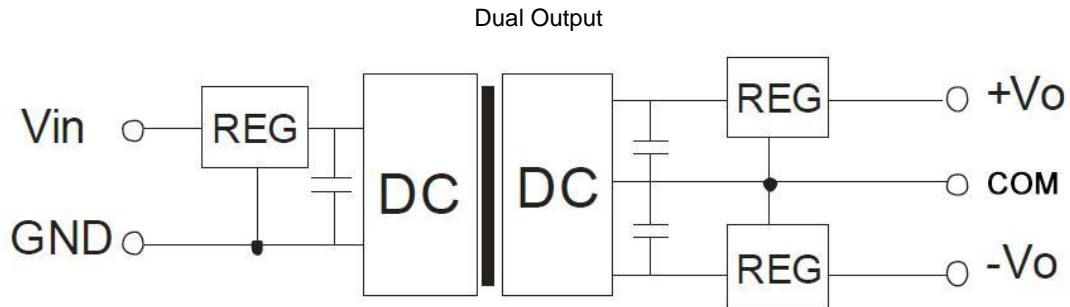

Note:

- 1.This product cannot be used in parallel, and do not support hot-plugging;
- 2.If the product works below the minimum required load, it cannot guarantee that the product performance meets all performance indicators in this manual;
3. All index testing methods in this datasheet are based on our Company's corporate standards
4. The product specification may be changed at any time without prior notice.